



V950 Gate valve



specification

- all sizes rated PN16
- BS EN 1171:2002
- flanged to EN1092-2 PN16
- ductile iron gate valve
- bronze (gunmetal) seat and trim
- stainless steel stem
- non-rising
- ductile iron body

DN	Connection	Code	Total (kg)	Cv	Kv
DN50	2"	15510	12.0	269.10	230.0
DN65	2 1/2"	15511	16.9	421.20	360.0
DN80	3"	15512	19.1	607.23	519.0
DN100	4"	15513	26.6	1079.91	923.0
DN125	5"	15514	37.9	1688.31	1443.0
DN150	6"	15515	47.4	2430.09	2077.0
DN200	8"	15516	73.9	4320.81	3693.0
DN250	10"	15517	122.0	6752.07	5771.0
DN300	12"	15518	171.0	9722.70	8310.0

*Cv - flow rate in US GPM at a pressure drop of 1 psi.
 *Kv - flow rate in m3 per hour at a pressure drop of 1 bar.

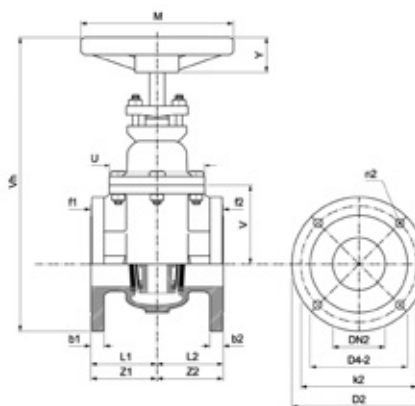

Dimensions (mm)

	b1/b2	d2-1/d2-2	d4-1/d4-2	D1/D2	Do1/DO2	DN1/DN2	f1/f2	k1/k2	L1/L2	M	n1/n2	U	V	Vh	Y	Z1/Z2
DN50	19.0	19.0	99.0	165.0	60.0	2"	3.0	95.0	89.0	180.0	4.0	114.0	209.0	323.0	30.0	89.0
DN65	19.0	19.0	76.0	118.0	76.0	2 1/2"	3.0	106.0	95.0	180.0	4.0	122.0	234.0	358.0	30.0	95.0
DN80	19.0	19.0	88.0	200.0	132.0	3"	3.0	122.0	101.0	200.0	4.0	130.0	292.0	423.0	30.0	101.0
DN100	19.0	20.0	114.0	215.0	156.0	4"	3.0	138.0	114.0	250.0	4.0	141.0	334.0	475.0	30.0	114.0
DN125	19.0	20.0	139.0	250.0	184.0	5"	3.0	188.0	127.0	280.0	4.0	154.0	382.0	538.0	30.0	127.0
DN150	10.0	20.0	168.0	285.0	211.0	6"	3.0	206.0	133.0	300.0	4.0	167.0	446.0	620.0	30.0	133.0
DN200	20.0	21.0	219.0	350.0	266.0	8"	3.0	281.0	146.0	360.0	4.0	192.0	553.0	755.0	32.0	146.0
DN250	22.0	21.0	273.0	400.0	319.0	10"	3.0	330.0	165.0	360.0	4.0	218.0	675.0	910.0	34.0	165.0
DN300	24.0	22.0	323.0	456.0	370.0	12"	3.0	368.0	178.0	410.0	4.0	243.0	52.0	1017.0	37.0	178.0

Material specification

Nr	Component	Material
1	Body	Ductile iron
2	Body seat ring	Bronze (Gunmetal))
3	Bonnet	Ductile iron
4	Bonnet bush	Brass
5	Bonnet gasket	Graphite non-asbestos
6	Stem	Stainless steel
7	Stem nut	Brass
8	Wedge	Ductile iron
9	Wedge seat ring	Bronze (Gunmetal))
10	Wedge trim	Bronze (Gunmetal))
11	Wedge nut	Bronze (Gunmetal))
12	Gland follower	Ductile iron
13	Gland	Ductile iron
14	Gland packing	Graphite non-asbestos
15	Stuffing box	Ductile iron
16	Stuffing box gasket	Compressed graphite
17	Handwheel	Cast iron
18	Bolt	Steel
19	Nut	Steel

Maximum pressure conditions

Size	Max Pressure (bar)	Min/Max Temperature (°C)	Test Pressure Shell (bar)	Test Pressure Seat (bar)	Max Pressure (psi)	Min/Max Temperature (°F)	Test Pressure Shell (psi)	Test Pressure Seat (psi)
DN50 to DN300	16.0	-10°C + 180°C	24.0	17.6	232.1	14°F + 356°F	348.1	255.3

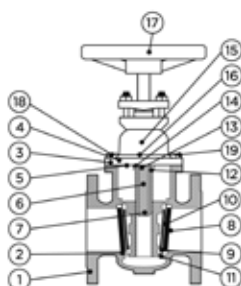

Pressure equipment directive category

All sizes classified SEP